

## Unlock Your Creativity: Discover the Secret to Crafting the Perfect Tufting Frame for Stunning DIY Projects!

Tufting has emerged as a beloved technique among DIY enthusiasts, allowing for the creation of unique and beautiful textile pieces. From plush rugs to cozy wall hangings, tufting offers endless possibilities for personal expression and creativity. However, to achieve the best results, having a sturdy and well-designed [tufting frame](#) is essential. A custom-built frame not only enhances your crafting experience but also ensures that your projects turn out beautifully. By taking the time to build your own tufting frame, you unlock a world of creative potential, enabling you to bring your artistic visions to life.

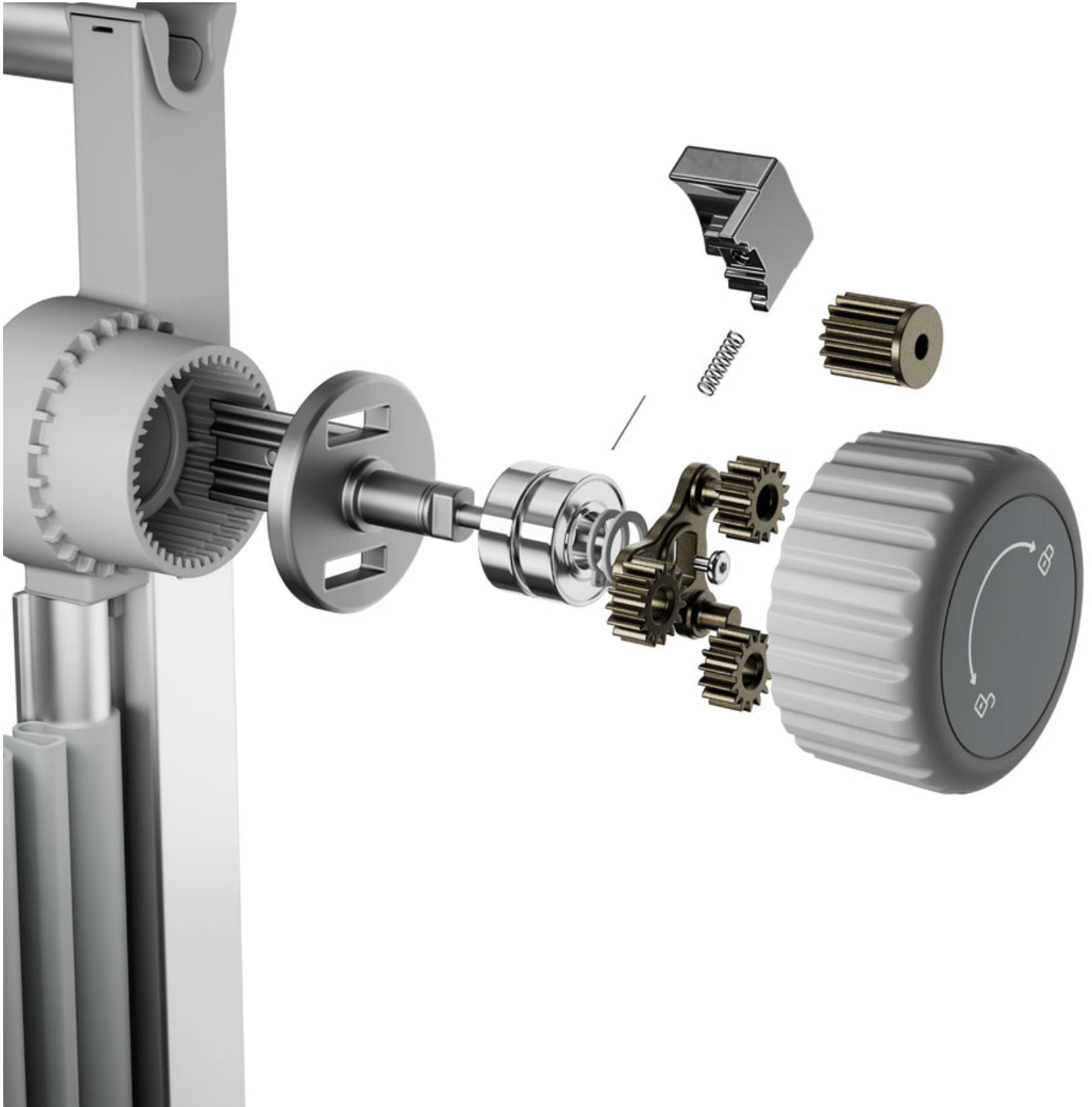

### Understanding Tufting and Its Benefits

Tufting is a versatile technique where yarn is threaded through a backing material to create a plush and textured surface. This method is popular in various applications, particularly in home decor, where it can be used to make everything from cushions to intricate wall art. The benefits of tufting are numerous: it allows for complete customization, enabling you to choose your colors, patterns, and textures. Additionally, tufting is a fulfilling creative outlet; there's a unique satisfaction that comes from crafting something by hand, knowing that each piece is a reflection of your personal style. Whether you're a seasoned crafter or a beginner, tufting can be a rewarding endeavor that transforms your living space.

### Essential Materials for Building a Tufting Frame

To construct a tufting frame, you will need several essential materials. First and foremost, sturdy wood, such as pine or plywood, will serve as the frame's foundation. You'll also need screws for assembly, fabric for the backing, and tools like a saw, drill, and measuring tape. Choosing high-quality materials is paramount for durability; opting for thicker wood can provide added stability. Additionally, consider using a softwood for easier manipulation, especially if you're new to woodworking. If you're unsure about your material choices, consulting with a local hardware store or seeking advice from experienced crafters can help you make informed decisions.

## **Step-by-Step Guide to Crafting Your Tufting Frame**

Building your tufting frame can be a straightforward process if you follow these steps. First, measure and cut your wood to the desired dimensions. A typical frame might be around 36 inches by 48 inches, but feel free to adjust based on your project needs. Once you have your pieces, assemble the frame by connecting the sides with screws, ensuring everything is square and level. To enhance stability, consider adding diagonal supports in the corners. After assembling, sand the edges to prevent splinters and improve the overall finish. Finally, attach your backing fabric to the frame securely, ensuring it's taut yet not overly stretched. A well-constructed frame will provide a solid base for your tufting projects, making the crafting process smoother and more enjoyable.

## **Optional Features for Your Tufting Frame**

While the basic tufting frame is functional, you might want to consider adding optional features to enhance its usability. For instance, an adjustable height mechanism can make your frame more comfortable to work with, accommodating different crafting styles and preferences. Adding wheels can also improve mobility, allowing you to easily move the frame around your workspace. If you plan to tackle larger projects, additional supports can be beneficial, ensuring stability as you work on more extensive tufting pieces.

## **Tips for Using Your Tufting Frame Effectively**

Once your tufting frame is ready, it's time to dive into the crafting process! Begin by setting up your fabric, ensuring it is securely attached and evenly tensioned across the frame. Adjusting the tension is crucial; too loose, and your stitches may not hold; too tight, and it could cause distortion. As you work, keep an eye on the fabric's alignment to prevent any misplacement of your design. If you encounter issues, such as uneven tufting or yarn tangles, take a moment to troubleshoot rather than push through. Remember that crafting is a learning process, and each project will teach you something new. Listening to your frame and adjusting as needed will lead to a more satisfying tufting experience.

## **Enhancing Your DIY Experience with a Tufting Frame**

In summary, creating your tufting frame is a rewarding step in your DIY journey that can significantly enhance your crafting experience. By understanding the art of tufting and gathering the necessary materials, you can build a sturdy foundation for your projects. Remember to consider optional features that suit your needs and to apply effective crafting techniques. As you embark on this creative journey, let your imagination guide you, transforming simple yarn and fabric into stunning pieces of art that reflect your personal style. Crafting is not just a hobby; it's a fulfilling experience that can bring joy and beauty into your life and space.